

**synthesis  
technology**

**MOTM-850 Pedal Interface  
Assembly Instructions & Owner's Manual**

Synthesis Technology  
6625 Quail Ridge Dr.  
Fort Worth, TX 76180  
(817) 281-7776  
[www.synthtech.com](http://www.synthtech.com)

Oct. 25, 2001

# MOTM-850 PARTS LIST

Please carefully check that all parts are in your kit. If you have a suspected shortage, please call or email. If you get free extra stuff, keep it for next time.

**Capacitor** bag, containing the following 10 parts:

4ea 10mfd, 50V Electrolytic	C3, C6, C7, C8
6ea 0.1mfd (marked 104) ceramic axial	C1, C2, C4, C5, C9, C10

**Resistor** bag, containing the following 24 parts:

5ea 10K (brown, black, orange)	R1, R6, R8, R14, R19
4ea 47K5 1% (yellow, violet, green, red)	R12, R13, R20, R23
3ea 820 ohm (gray, red, brown)	R3, R7, R22
2ea 332K 1% (orange, orange, red, orange)	R2, R24
2ea 68K (blue, gray, orange)	R4, R5
2ea 180K (brown, gray, yellow)	R9, R10
2ea 715K 1% (violet, brown, green, orange)	R15, R21
1ea 620K (blue, red, yellow)	R11
1ea 100K 1% (brown, black, black, orange)	R16
1ea 82K5 1% (gray, red, green, red)	R17
1ea 16K5 1% (brown, blue, green, red)	R18

**IC** bag, containing the following 5 parts:

1ea 2N3904 NPN transistor	Q1
1ea LM311N comparator	U1
1ea LM78L12 +12V TO-92 regulator	U2
1ea LM79L12 -12V TO-92 regulator	U3
1ea LT1013 precision dual op amp	U4

**Misc #1** bag, containing the following 6 parts:

2ea Axial ferrite beads (plain, gray things)	L1, L2
1ea MTA-156 power connector	JP1
2ea 3-pin header with shunt	JP2, JP3
1ea red LED, panel mount	D1

**Knobs**, 4ea, ALCO PKES90B1/4

**Jacks**

1ea Switchcraft 112B stereo jack	J1
3ea Switchcraft 112A mono jack	J2, J3, J4

- Pots**, 4ea containing the following:  
4ea 100K cermet Spectrol 149-71104 VR1 – VR4
- Front panel**
- Mounting bracket**
- Wire bag**, containing the following 6 wires:  
3ea RG-174 coax, 4 ½ inches  
1ea 2-wire set, 22ga. 3 inches (red/black)  
1ea 3-wire set, 22ga 2 inches (orange, white, gray)  
1ea Power Cable, 20"
- Hardware bag**, containing:  
4ea #8-32 x 3/8 black screws (for mounting module to rack)  
4ea #6-32 x 1/2 zinc screws (for attaching pc board to bracket)  
4ea 1/4 inch aluminum spacers  
6ea #6 KEPS nuts (2 for attaching bracket to front panel, 4 for pc board)  
2ea small heat-shrink tubing  
4ea small tie-wraps
- Organic Solder**
- No-clean Solder**
- PC Board**, MOTM-850

## GENERAL INFORMATION

Thank you for purchasing the MOTM-850 Pedal Interface. If you have any issues concerning the building or use of the kit, please contact us at (817) 281-7776 or by email: [syntht@yahoo.com](mailto:syntht@yahoo.com)

This kit should take the average builder between 2 to 3 hours. The kit contains many different resistors and special parts. However, please remember this is NOT a speed contest; it is an accuracy contest. There is no rule that you have to complete the entire kit in one day (as long as you wash the flux off!).

Successful kit building relies on having the proper tools. Here is a list of what you will need to build your MOTM-850:

- Soldering iron, 50W max power
- Needle-nose or chain-nose pliers
- Diagonal cutters
- Allen key set for securing the knobs (1/16" or 1.6mm)
- Magnifying glass: to read the capacitor codes and to inspect solder joints
- Lead bending tool (optional, but makes the job go much faster)
- DVM (Digital Volt Meter) or oscilloscope (to check the output)
- #1 Philips screwdriver
- Fingernail brush for washing off the organic flux
- Old towel for blotting dry pc board
- ***Heat-shrink gun is highly recommended!***

For more information of tools used and suggestions, see the MOTM FAQ and Tutorial pages at <http://www.synthtech.com>.

## HOW TO FOLLOW THE DIRECTIONS

Please read the entire instruction before proceeding. There may be valuable information at the end of the instruction. Each instruction has a check box  next to it. After you complete the instruction, check the box. This way you can keep track of where you are in the process.

## VERIFY THE PARTS LIST

- Verify that all of the parts are in the kit as shown on the parts list.

## A WORD ON SOLDERING

There are 2 very different types of solder used in the kit. Most of the soldering uses ‘Organic Flux’ solder. ***This is strictly for use on the pc board, and is NOT to be used on the front panel wiring!***

In order for solder to ‘stick’ to the copper, a chemical called ‘flux’ is embedded in the solder. The flux leaves a residue on the pc board that should be cleaned with warm water. **DO NOT USE SOAP OR OTHER CLEANSERS.** Most of the parts in the kits are ‘waterproof’ and can be washed in the sink. The flux is OSHA approved for flushing down the drain, so don’t worry about that! A soft brush is used to gently scrub the board. We recommend a ‘fingernail brush’, which is about 1” x 2” and can be found for about \$1.

The other type of solder is called ‘No Clean Flux’; because as the name implies it does not require washing. This solder is used for wiring the pots, switches, jacks, etc. This solder is harder to use on the pc board; because even when melted, it is not very fluid (about the consistency of toothpaste). We will use it **VERY SPARINGLY** on the pc board.

OK, let’s get started on the board!

### PART #1: SOLDERING THE RESISTORS

Since there are more resistors than anything else, we will start here. If you do not know the resistor color code, refer to the parts list. Resistors are not polarity sensitive, but the board will be easier to debug (and look nicer) if you point the first color band in the same direction for all the parts. The color code is also in the README FIRST document that every customer receives with his or her first order.

You will start by soldering in **ALL** of the resistors.

- Find the **RESISTOR** bag.
- Find the MOTM-850 blank pc board. There is a copy (larger than actual size) of the silkscreen which shows where the parts go at the end of this document. It will be useful if you locate the part on the print first, put the part in the board, then ‘check off’ the silkscreen. All parts are inserted from the side of the board with the white silkscreen (the “top” side).

NOTE: some reference designators are under the resistor! Be careful.

- We will stuff the resistors by value to make things easier. The resistors (and other long-leaded parts) are inserted on a 0.4 inch spacing. The important thing is to be sure that the part is sitting all the way down on the board. Push the leads in the holes, push the part on the board, and then bend the leads on the bottom outwards to a 45 degree angle (roughly!). This is called ‘cinching the leads’: and keeps the part from falling out! From the bottom of the board, solder (using the organic flux), applying heat to the pad for about a half second first, then applying just enough solder to make a small puddle that looks like a tiny pyramid. Enough solder should

flow in the hole such that on the top (component) side, a small amount is on the top pad as well

There are many 1% resistors in this kit. They have light blue body color, and sometimes the color bands are difficult to read. When in doubt, use a DVM to measure the value. NO guessing!

The rule of soldering: don't use too much, you can always add more! Cut the leads flush with the top of the solder joint with your diagonal cutters.

Locate the 10K resistors (5pcs). Solder the resistors into R1 (by VR3), R6 (left of U3), R8 (above VR3), R14 (above R8) and R19 (right of C10).

- Locate the 47K5 1% resistors (4) and solder into R12 and R13 (left of U4), R20 (above R19), and R23 (top edge of pcb by C5).
- Locate the 820 ohm resistors (3) and solder into R3 (left of U1), R7 (between VR2 and VR3), and R22 (by J2).
- Locate the 332K 1% resistors (2) and solder R2 (above C1), and R24 (by VR1).
- Locate the 68K resistors (2) and solder into R4 and R5 (above VR3).
- Locate the 180K resistors (2) and solder into R9 and R10 (beside VR2).
- Locate the 715K 1% resistors (2) and solder into R15 (left of U4) and R21 (right of U4).
- Locate the 620K resistor and solder into R11 (between R20/R21).
- Locate the 100K 1% resistor and solder into R16 (left of VR3).
- Locate the 82K5 1% resistor and solder into R17 (above R16).
- Locate the 16K5 1% resistor and solder into R18 (above R17).

## **PART #2: BOARD WASH #1**

- Verify all the resistors are in the correct position.
- Verify all the resistors are flat on the board. Correct if needed. Check solder joints.
- Wash the board in warm water, gently scrubbing *both* sides. DO NOT USE ANY SOAP! Just water!

- Shake the board a couple of times, blot dry with an old towel (the leads will frazzle a good towel). Let dry at least 15 minutes.
- Take a little break! You are about 1/3rd of the way finished.

### **PART #3: CAPACITORS**

- Locate the **CAPACITOR** bag.
- Locate the 0.1mfd axial ceramic caps (6) and solder into C1, C2, C4, C5, C9 and C10. Note that these are bent on 0.3" centers.
- Locate the 10µfd electrolytics (4). Note that there is a stripe on the **NEGATIVE** terminal. The pc board has a + on the **POSITIVE** terminal. Carefully stick the capacitors into C3, C6, C7 and C8 with the stripe **away** from the + pad on the board. All the capacitors will 'face' the **SAME DIRECTION**.

### **PART #4: MISC and IC STUFF**

Almost done with the parts on the pc board! This will finish up the soldering with the organic flux.

- Locate the **MISC #1** bag and the **IC** bag.
- Locate the ferrite beads (2). They are axial parts, gray colored with no markings. These are non-polar, and are soldered into L1 and L2 (by JP1).
- Locate the MTA-156 power connector. Solder into JP1. Note that the connector has a 'locking tab' on one side. This side is the "inside" facing relative to the pc board. Note the silkscreen symbol for JP1 has a line on one side, indicating this is the side where the locking tab goes.
- Locate the MXL1013 op amp. Solder into U4. Note that all ICs are pointing "up" towards the top edge of the pc board (if you call where the pots are the 'bottom' edge). The IC will have a 'notch' or indentation in the top by Pin #1.
- Locate the LM311 comparator. Solder into U1.
- Locate the 2N3904 transistor. **DO NOT GET IT CONFUSED WITH THE 2 VOLTAGE REGULATORS!!** Solder into Q1.

- Locate the LM78L12 voltage regulator. **DO NOT GET IT CONFUSED WITH THE 79L12 REGULATOR!!** Solder it into U2.
- Locate the LM79L12 voltage regulator. Solder it into U3. Save the LED for later.
- Apply a small bit of solder to the via holes. These are the small pads that allow traces to “change sides” of the pc board. **DO NOT SOLDER PADS FOR THE REMAINING COMPONENTS!!** As an example, if you look at the mounting hole by J1, you will see 3 via holes around it.
- Solder the 2 3-pin header strips into JP2 and JP3. Remove the blue shunts and **DON'T LOSE THEM!**

## **PART #5: FINAL BOARD WASH & INSPECTION**

- Verify all the parts are in the correct locations. Make sure all of the ICs are pointing the same direction. Make sure the 3 TO-92 parts (transistor/voltage regulators) are facing the same direction.
- Inspect the solder joints. Any solder shorts? Too much solder? Missing joints?
- Wash the board under warm water. Scrub gently. Dry.

**THIS IS A GOOD STOPPING PLACE TO REST OR PUT THE KIT AWAY UNTIL LATER.**

*You are now finished with the Organic flux solder. All soldering past this point is using the No-Clean solder. You do not have to wash the board anymore.*

## **PART #6: FINISHING THE PCB**

You will now solder in the remaining parts on the pcb in preparation for wiring to the front panel. **USE THE NO-CLEAN SOLDER. BE CAREFUL!**

- Locate the Spectrol pots. They mount into VR1-VR4. Be sure they are flat and sticking out perpendicular to the pc board.
- Locate the 3 pieces of RG-174 black coax cable. Again, note that one end has longer wires stripped than the other. The short ends will go in the pc board in locations J2, J3 and J4. Look at the pc board. Notice that in the coax positions, there is a large hole pad (lower pad) and a smaller pad (top hole). The braided wire is soldered into the larger hole. The smaller, inner conductor goes in the top hole. **BE SURE THE *SHORTER* BRAIDED END GOES INTO THE PC BOARD.**



Solder each coax cable into the holes. Attach a tie-wrap to secure the coax cable flush to the board. The tie-wrap goes down, into the left hole and up through the right hole. Secure and trim off any excess.

- Find the red/black twisted wire. It goes into D1. Solder the Red wire into pad #1 and the Black wire into pad #2.
- Find the orange/white/gray wire. It solders into J1. The White wire goes in pad #1, the Orange wire into pad #2 and the Gray into pad #3. Carefully cut the ty-wrap off the bundle first and discard. There is another ty-wrap used to secure the 3 wires in a bundle to the pcb.

***YOU ARE NOW FINISHED WITH THE PC BOARD WORK! BREAK TIME.***

## **PART #7: FRONT PANEL PREPARATION**

You will now attach components to the front panel. It is **HIGHLY** recommended that you use a set of hollow shaft nut drivers, **NOT PLIERS**, to tighten the nuts. This prevents scratching. **NOTE:** all references to part orientation is from the **REAR** of the panel.

- Locate the 4 Switchcraft jacks. Notice that from the rear, there is a beveled corner. This corner is **ALWAYS CONNECTED TO GROUND, USUALLY WITH A BRAIDED CONDUCTOR**. Each jack has a flat washer, a lockwasher, and a ½” hex nut. Remove the nuts and washers from each jack. Place aside. Keep the lockwasher on the jacks. Also, one of the jacks has 3 lugs, but in a ***different location*** that the others. This jack is for the pedal to plug into, and it **MUST** go into the **PEDAL** hole.
- Insert the 4 jacks/lockwashers, with the beveled corner in the ***upper right*** corner, into the 4 holes. Be sure the jack in the **PEDAL** hole has the lug in the ‘bottom’ position, when viewed from the rear. Place the flat washer on the jack, then the hex nut. Hold the jack with one hand on the backside, keeping it ‘square’. Tighten the hex nut with a nut driver. **NOTE:** when tight, not much of the exposed threads of the jack are exposed.

You are now ready to attach the pc board to the bracket and then wire up to the panel.

## **PART #8: ATTACH PC BOARD TO BRACKET/PANEL**

- In the **HARDWARE** bag, locate 4 #6-32 x 1/2 screws, 6 #6 KEPS nuts, and 4 spacers.
- Locate the mounting bracket. The pc board attaches to the bracket, with the 4 screws threading from the top of the board, through the spacers, through the bracket, and then out the bottom of the bracket. The #6 KEPS nut attaches on the bottom of the bracket. Note the bracket has 2 long mounting flanges with a hole

in each. These attach to the 2 threaded studs sticking out of the rear of the panel. The 4 pots each stick in its panel hole when the bracket is screwed down on the 2 threaded posts.

Attach the pc board to the bracket. The flanges will point upwards when the pc board is sitting on the bracket. Note that the bracket holes for the pc board are actually oblong. This is to allow adjustment for the pc board to firmly press up against the back of the panel. As a start, set the 4 screws **ALL THE WAY TO THE LEFT** of the oblong holes. **Loosely** tighten the 4 KEPS nuts on the bottom.

- ☐ **THIS IS A VERY IMPORTANT STEP, SO PAY ATTENTION AND READ ALL OF IT BEFORE PROCEEDING!**

Note that each of the 4 pots on the pc board have 2 hex nuts and a flat washer. Remove the first hex nut and the washer. Set aside.

What you will do now is adjust the remaining hex nuts so that when the bracket is all the way down on the panel's threaded studs, all the pot hex nuts touch the rear of the panel.

Screw (by hand) each hex nut on the pots so that it is all the way on (touching the face of the pot). Now, pick up the pc board/bracket assembly and carefully slide it over the 2 threaded studs, making sure the pots are aligned in the holes. Use 2 #6 KEPS nuts and tighten the bracket to the panel.

- ☐ Loosen the 4 KEPS nuts on the bottom of the bracket. Slide the pcb **ALL THE WAY TO THE RIGHT AS FAR AS IT WILL GO**, so that the 4 pot nuts are all pressing against the panel. By hand, put hex nuts on the outside threads of VR1 and VR4 to keep the pc board in place. Now, tighten the 4 KEPS nuts on the bracket. The pcb and bracket should be secure, with no gaps visible between the panel and the pot nuts. You may need to loosen the nuts on the pots, so that they are touching the back of the panel. Again, make sure each pot's nut is touching the back of the panel (no gaps!). There will be a gap from the edge of the *pc board* to the panel.
- ☐ Remove the hex nuts on VR1 & VR4. For all of the pots, first put on the flat washer, then the hex nut. Tighten with a ½" nut driver.

## **PART #9: FINISH WIRING TO THE PANEL**

Please read the following instructions carefully. In order to neatly attach the many wires to the front panel components, the wires are soldered in a specific order.

- ☐ Find the red LED assembly. Note that one lead is slightly longer. This is the Anode, and it is soldered to the Red wire in D1. The other lead is the Cathode, and is soldered to the Black wire. Insert the LED through the panel, with the longer Anode lead towards the top panel edge (looking from the rear, this is towards the "left").

Press the LED snugly to the panel. Now, cut off half of the LED's leads (they are too long!). Place the 2 pieces of heat-shrink tubing down over the Red/Black wires. With a pair of chain-nosed pliers, make a small 'J' hook in each LED lead. Then, make 'J' hooks on the Red and Black wires. Mate the Red wire to the Anode lead, and solder. Do the same with the Black lead and the Cathode. After waiting 20 seconds for cooling, slip the heat-shrink tubing all the way down until they touch the back of the LED case. Use a heat gun on LOW setting to shrink the tubing. You can also use the soldering iron, hold it very close BUT NOT TOUCHING the tubing.

- Now you will solder to the 4 jacks. Each jack has 3 lugs: from the rear we will refer to them as LEFT, TOP, BOTTOM (for J1) and BEVELED. The TOP lug is for the switched contact: this is a NC (normally closed) contact that is opened when a plug is inserted. In all 3 cases, this lug is NOT USED.
- Solder the coax in J4 to the CV OUT jack. The braid goes to the **BEVELED** lug. The inner conductor goes to the **LEFT** lug. This is true of ALL coax wires. Use enough solder to completely fill in the hole on the lug.
- Solder the coax in J2 to the MIX IN jack.
- Solder the coax in J3 to the GATE jack.
- Solder the orange/white/gray wire in J1 to the PEDAL jack. The Orange wire goes to the BOTTOM lug, the White wire goes to the LEFT lug and the gray wire goes to the BEVELED lug.
- Rotate all of the front panel pots fully counter-clockwise. Locate the **KNOBS**. Notice each knob has a white line on it. Place the knob on the pot shaft, align the white line to the '0' tick mark, and tighten the hex screw. The silver part of the knob has a protective clear plastic overlay that can be removed if desired. Gently rub with your fingernail across it and it will peel off. Use the extra wire tie to "bundle" the coax wires

\*\*\*\*\*  
**CONGRATULATIONS! YOU HAVE FINISHED BUILDING THE MOTM-850!**  
\*\*\*\*\*

All that's left to do is test it! But before we do, please read the following Theory of Operation.

## THEORY OF OPERATION

The MOTM-851 consists of 2 separate circuits: the voltage drive to the pedal and the scaling/offset, and the Gate extractor.

The MOTM-850 can interface to 2 basic types of pedals: resistive and voltage-out. Resistive pedals use a 3-conductor (stereo) plug, because 3 signals are needed: ground, voltage IN and voltage OUT. CV Out pedals use a 2-conductor plug (mono) and only needs ground and CV OUT.

The pedals we will use as examples for 'resistive' types are the Roland EV-5 and the Yamaha FC7/FC9 series. They are probably others, but these two cover the kinds you are likely to use.

In general, the resistive pedals are nothing more than a simple potentiometer (pot) in a fancy case. The pot is used as a voltage divider to output 0 to +5V. This in turn feeds the range/offset circuits and the Gate extractor.

This all sounds simple enough, but to make matters...errrrr....'interesting' Yamaha and Roland, on *purpose*, wired their pedals up differently, and use different pot values. But, being the clever people that we are, these differences are compensated for in the design of the MOTM-850.

Before we go into how the 3 types of pedals are dealt with, let's look 'downstream' at the other circuitry.

Dual precision op amp U4 (MXL1013 type) is used to 'condition' the output voltage from the pedal to a wide range of possible outputs. U4A is a 'reversible attenuator' with unity gain. The RANGE pot VR1 splits the pedal voltage into an inverter (U4A) to 'straight through' to inverting summer U4B. We can also add in an external signal MIX IN through VR4 and R15. Note that in the U4A stage, the MIX IN signal is attenuated by the ratio of R12/R15, but the gain is 'made up' by the ratio in U4B of R21/R23 to have unity gain end-to-end.

U4B can also add in DC offset via pot VR2. Resistors R9 and R10, along with some gain provided by the ratio of R21/R11, limit the DC offset to +-2.5V.

Resistors R14 and R19 are used to balance the DC offset voltage at the op amp's + and - terminals, due to input bias currents. This greatly reduces DC temperature drift.

OK, that's pretty straightforward, but what about resistor R24? What is it doing? This is the 'clever' part of the circuit! This is called a 'warping' resistor, because the pedal output is non-linear with pedal angle. We will talk about this resistor in the next section.

The Gate extractor is comparator U1. GATE pot VR3, along with resistors R4 and R5, set the trip point to +-5V. Hysteresis is set by R2 and R6. The 'width' of the hysteresis is set "wide" (about 0.5V) on purpose. It makes false triggering of the Gate output greatly reduced as you wail away on the pedal. If you think it's too wide, increase R2 to 560K.

The op amp and comparator are powered off separate +12V supplies by U2 and U3. This is done for several reasons. First, it provides a load-isolated voltage reference for the OFFSET and GATE pots (the pedal doesn't need this). Second, it isolates current spikes from the +15V line as the LED switches on and off.

The LM311 output is open-collector, so R3 provides the pullup.

The GATE signal can be selected to be positive-true (VTRIG) or shorting-to-ground (STRIG). Moog uses STRIG, everybody else uses VTRIG. Jumper JP2 selects which type is outputted to the jack. The output of the comparator is a VTRIG (rises to +12V when the comparator trips), and a simple transistor inverter Q1/R1/R8 provides STRIG. Q1 also is a 'free' way to drive the GATE LED D1, since we are turning on the LED by shorting it's cathode to ground (did I mention how clever we are?).

## INTERFACING TO THE ROLAND EV-5

The EV-5 pedal has 2 pots wired in series. The pedal mechanism pot is a 10K +-20% and a separate 'offset trimmer' pot of 50K. See Figure 1.

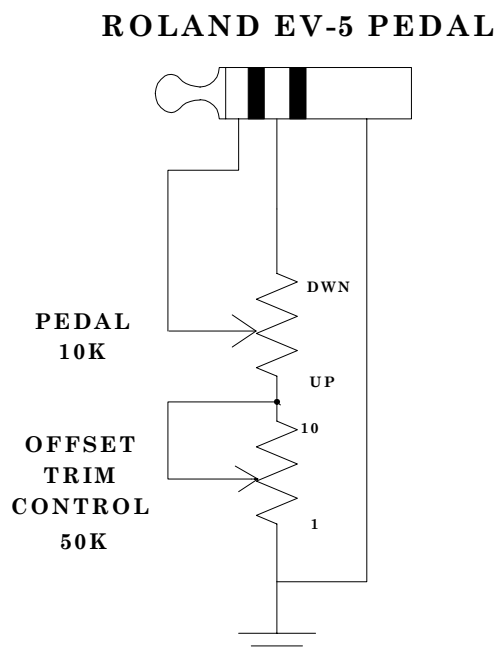

Assuming the trimmer pot is at dial position '0' (normal operation), the circuit is simple. The jumper JP3 is set to feed +15V through R18 (16K5). The output is from the wiper and is given by the equation:

$$V_{out} = 15 * (R_{down}) / (R_{down} + 16500 + 10000)$$

Where 16500 is the value of R18 and 10000 is the value of the pedal pot. Rdown is the fractional resistance of the 10K pot as you press down.

From this the maximum voltage out is when the pedal is all the way down, and the resistance is 10K, or:

$$V_{out} = 15 * (10,000/26,500) = 5.66V$$

In reality, we measured 3 different EV-5 pedals and found the pot to be closer to 9200 ohms, which limits the output to almost exactly 5.0V. Close enough!

The 'offset trimmer' simply adds resistance to the *ground* side of the pedal pot. If the trim is set to '10', or 50K, the output will 'lift off ground' and be from 9.6V to about 11.4V. This is out of the '850s operating range. So, be sure to keep that trim set below '3' or so!!

## INTERFACING TO THE YAMAHA FC PEDAL

The Yamaha pedals do not have the additional trimmer. It's just a single 50K pot. BUT, as we said earlier, they switched the tip and ring connections around! See Figure 2.

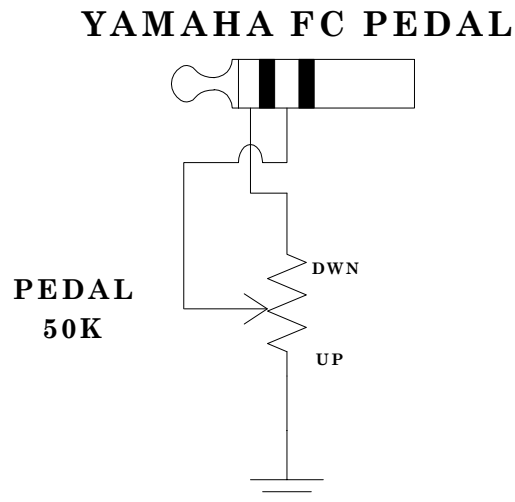

Since the pedal pot is 50K (they must use better pots, because the 4 we measured were all within 2% of 50K!), we need about 100K of 'series' resistance to get out 0 to +5V output. The voltage output in the Yamaha configuration is complicated, because we are 'driving' the wiper of the pot! The series combination of R17 and R18 is 99K. So, the maximum voltage out is:

$$V_{max} = 15 * (50/(99+50)) = 5.03V$$

If you really want to go through the math of the actual voltage out versus pedal position, please go ahead :)

Now, lets talk about R24. The clever reader will plot these out and see that the voltage out is non-linear with pedal position. This is because the voltage divider is based on the  $x/(1-x)$  curve. So, since we are perfectionists, R24 is added. The value is quite large, compared to the pedal resistances AND to the RANGE pot VR1. This adds it's own 'series resistance' to the wiper of VR1. Since the voltage output from the pedal is not buffered, and has a large

series resistance, R24 then enters into the overall transfer function to ‘warp’ the  $x/(1-x)$  pedal output. Rather than go through 5 pages of algebra, let it be said this value was picked empirically. That is, we stuck different values in there until satisfied. We may be perfectionists, but know the value of a good resistor decade box :)

## INTERFACING TO CV OUT PEDALS/MODULES

The third type of pedal runs off of batteries, and outputs a DC voltage directly. For these pedal types, or to process external voltages such as the output of a MOTM-800 EG, the blue jumper shunt is removed from JP3. You can also ‘park the shunt’ by sticking only one pin of the header into the shunt, so the other half of the shunt is sticking out over the pc board. See Figure 3. This prevents you from losing the shunt if you change pedal types.

### PARKING THE SHUNT

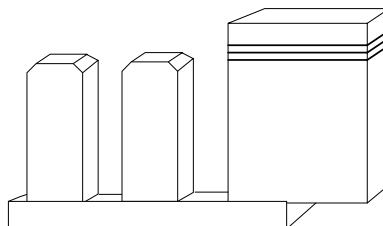

With the shunt removed, the additional resistor R16 is added into the series resistance. If you have a pedal with a 100K pot, this makes the total series resistance 199K so the output voltage is again 0 to +5V.

Since CV out pedals use mono (2-conductor) plugs, the ‘ring’ connection is shorted to ground through R16+R17+R18. This doesn’t matter. The CV out from the pedal is to the Tip connection, which goes straight into R24. Since the output impedance of the CV pedal is low, R24 has no effect. The CV can be mixed, scaled and offset with ease.

## USING THE MOTM-850

This first thing is to determine which type of pedal you have. If you have a passive volume pedal (like the Ernie Ball), these will NOT work. If the pedal plug is a 3-conductor, then it is some sort of resistive pedal. With a DVM, measure the resistance between Tip and Ring as you move the pedal up and down. Note the maximum resistance, usually when the pedal is depressed all the way down. Use the following table to set the jumpers.

PEDAL RESISTANCE (MAX)	JP3 SETTING
5K - 15K OHMS	R
15K – 75K OHMS	Y
75K – 150K OHMS	OPEN/PARKED

It doesn’t matter if the Tip is the wiper of the pedal pot or not, the MOTM-850 circuitry will compensate.

If you have a CV out pedal (2-conductor plug, has batteries), remove or park the shunt in JP3. The following is a description of each control.

## RANGE

This control sets the *maximum* output voltage of the module, assuming OFFSET is set to zero. The output voltage is  $-5V$  to  $+5V$ .

## OFFSET

This is a DC voltage, which is *added* to the pedal output. The range is  $-2.5V$  to  $+2.5V$ .

The combination of RANGE and OFFSET allows you to set the total DC voltage range as the pedal is pressed from full up to full down. See the following table for some examples in using RANGE and OFFSET. **IMPORTANT NOTE! The expected DC output of the MOTM-850 is based on setting the jumper JP3 to generate a 0 to  $+5V$  voltage into R24 as the pedal is pressed from up to down. This may not be the case if the pedal pot is not 10K, 50K or 100K, or if your CV out pedal has a different range (say, 0 to  $+6V$  out). If you set JP3 incorrectly, the voltage out of the module may be much higher or lower than expected.**

So, assuming everything is set correctly, here are some expected outputs based on various RANGE and OFFSET knob settings.

RANGE SETTING	OFFSET SETTING	OUTPUT OF MOTM-850
$+5V$	0	0 TO $+5V$
0	Doesn't matter	OFFSET reading
$-5V$	$-2.5V$	$-2.5V$ to $-7.5V$
$-5V$	$+2.5V$	$+2.5V$ to $-2.5V$
$+2.5V$	$-2.5V$	$-2.5V$ to 0V
$+5V$	$+2.5V$	$+2.5V$ to $+7.5V$
$+5V$	$-2.5V$	$-2.5V$ to $+2.5V$

Several things can be seen from this table. First, if the RANGE is set negative, the output voltage of the module *decreases* as you press the pedal down. Second, you can use the OFFSET control to 'tune' the CV out of the module, while the RANGE control sets the overall 'swing' of the voltage. You can also think of OFFSET as what voltage the pedal outputs when all the way up (ie where the voltage 'starts from').

You can also control if the output voltage increases or decreases as the pedal is pressed. Pretty neat, huh?

A 'hidden' usage is not plugging in a pedal at all, and using the OFFSET control as a DC source, or to add DC offset to whatever is fed to the MIX IN.



## USING MIX IN

MIX IN is an optional input that is added, at unity gain, to the pedal output. The panel control MIX is a simple attenuator, so there is no gain associated with this signal. An example is to insert the CV out of a keyboard, and the MOTM-850 can add 'pedal portamento' effects or even theremin-type glides to VCOs. Remember, this is just a DC offset to the MIX signal, it's not a volume control function (VCA).

## USING THE GATE OUTPUT

The important thing to understand about the GATE control is how the LM311 actually is connected. The LM311 compares 2 voltages: the panel pot GATE and the instantaneous DC output of the module. If the voltage of the CV out jack **EXCEEDS** the setting of the GATE pot, the GATE is active and the LED lights up.

What can be confusing is the meaning of 'exceeds'. Since we are dealing in both positive and negative voltage polarities, you have to remember that the more negative a voltage is, the "smaller" with respect to positive voltages it is. Again, we are talking in relative, algebraic terms here, not 'real world'.

So, suffice to say that in terms of the GATE threshold, any positive voltage 'exceeds' a negative voltage. In other words, +1V 'exceeds' -7V, and -2V 'exceeds' -3V. Think of a number scale like you had in third grade, with 0 in the middle. Numbers to the 'right of 0' (positive) are 'bigger' than numbers to the 'left of zero' (negative). In general, a number to the right 'exceeds' any numbers to the left on the scale. Is this making ANY sense at all??!?

Why am I going on and on about this? Because you can set the GATE control to not activate all, or you may find the GATE is acting 'backwards' than expected.

Let's go over 3 cases, of which 2 are bad :)

### CASE #1: EXPECTED BEHAVIOUR

Let's use a simple case to start. We want the '850 to output 0 to +3V over the pedal range. So, we set RANGE to +3V and the OFFSET to 0V. Easy enough.

Now, we have to decide when the GATE 'triggers'. Let's pick the  $\frac{1}{2}$  point, when the pedal is  $\frac{1}{2}$  of the way down, AND the voltage is  $\frac{1}{2}$  of the maximum. Hmmmm...that's 1.5V. So, we set the GATE control to +1.5V.

Hey, it works great! Just about in the middle of depression, the GATE LED lights up, and stays lit until the pedal is upwards past the mid-point. As long as the pedal is down below the halfway point, then DC voltage out of the module EXCEEDS 1.5V and GATE is active.

### CASE #2: GATE THRESHOLD IMPROPERLY SET

This is an 'error', but an easy one to figure out. If in the above example you set GATE to +4V, the LED would never come on. That tells you the CV out of the module never exceeded the GATE threshold.

Conversely, if you set the GATE below 0, then the LED is on ALL THE TIME. That is because the pedal output always EXCEEDS the GATE threshold (remember, 0V is 'bigger' than any negative voltage in this circuit).

### **CASE #3: THE GATE BEHAVIOUR IS 'BACKWARDS'**

In 'normal' operation, you trigger the GATE at some point as the pedal is depressed, and it stays active until the pedal comes up.

However, if you set RANGE to  $-5V$  and OFFSET to 0, so that the module outputs 0V to  $-5V$  when pressed, AND you set GATE to  $-2.5V$  (the halfway point), you will notice the LED is lit (GATE ACTIVE) when the pedal is 'up' and turns off as the pedal goes 'down'.

Why? Because when the pedal is up all the way, the DC output is 0V, which EXCEEDS the GATE threshold of  $-2.5V$ .

### **GATE TYPE SELECTION**

There are 2 types of GATE signals in electronic synths: VTRIG and STRIG.

STRIG is Moog-specific! When GATE is INACTIVE, the GATE output is +12V. When GATE is ACTIVE, the GATE output is 0V. If you are using the MOTM-850 to control a Moog modular, Rogue, Source, MiniMoog or other Moog synth, be sure JP2 is set on STRIG.

VTRIG is the 'normal' setting for MOTM and other synths. This is the EXACT OPPOSITE of STRIG. VTRIG is 0V when inactive, and +12V when active.

That sums up how the module itself functions. How it's actually used in your MOTM system is entirely up to your imagination! You can use pedals to sweep filters, add PWM to VCOs, change the LFO rates, or any of 100 other functions.

### **TROUBLESHOOTING**

If your MOTM-850 does not work, please verify ALL of the following before contacting us. The following reference directions assume that you are looking at the pc board with the panel to the right and the power connector to the left.

- All of the ICs are pointing the same way (up, towards the edge away from the panel).
- The braided wire on the coax goes to the beveled side of the jacks.
- The parts are in the right places, none of the 4 orange electrolytics in backwards!
- No solder shorts or missing joints. If the LED doesn't light, check the module output with a DVM. Check JP3 for the proper setting.

# SPECIFICATIONS

## MOTM-850 Pedal Interface

Pedal resistances	10K, 50K, 100K nominal (jumper selectable)
DC output range	-7.5V to +7.5V nominal
GATE voltage	+12V max, 0V min.
MIX input range	-7V to +7V nominal

### CONTROLS

RANGE	Sets the over pedal response range
OFFSET	Sets the DC offset of the pedal
GATE	Sets the GATE threshold
MIX	Attenuates the signal applied at MIX IN

### GENERAL

Power Supply	-15VDC @ 10 ma nominal +15VDC @ 15 ma nominal
Size	1U x 5U 1.72" x 8.72" 44mm x 221.5mm
Depth behind panel	2.375 inches (60.3mm)

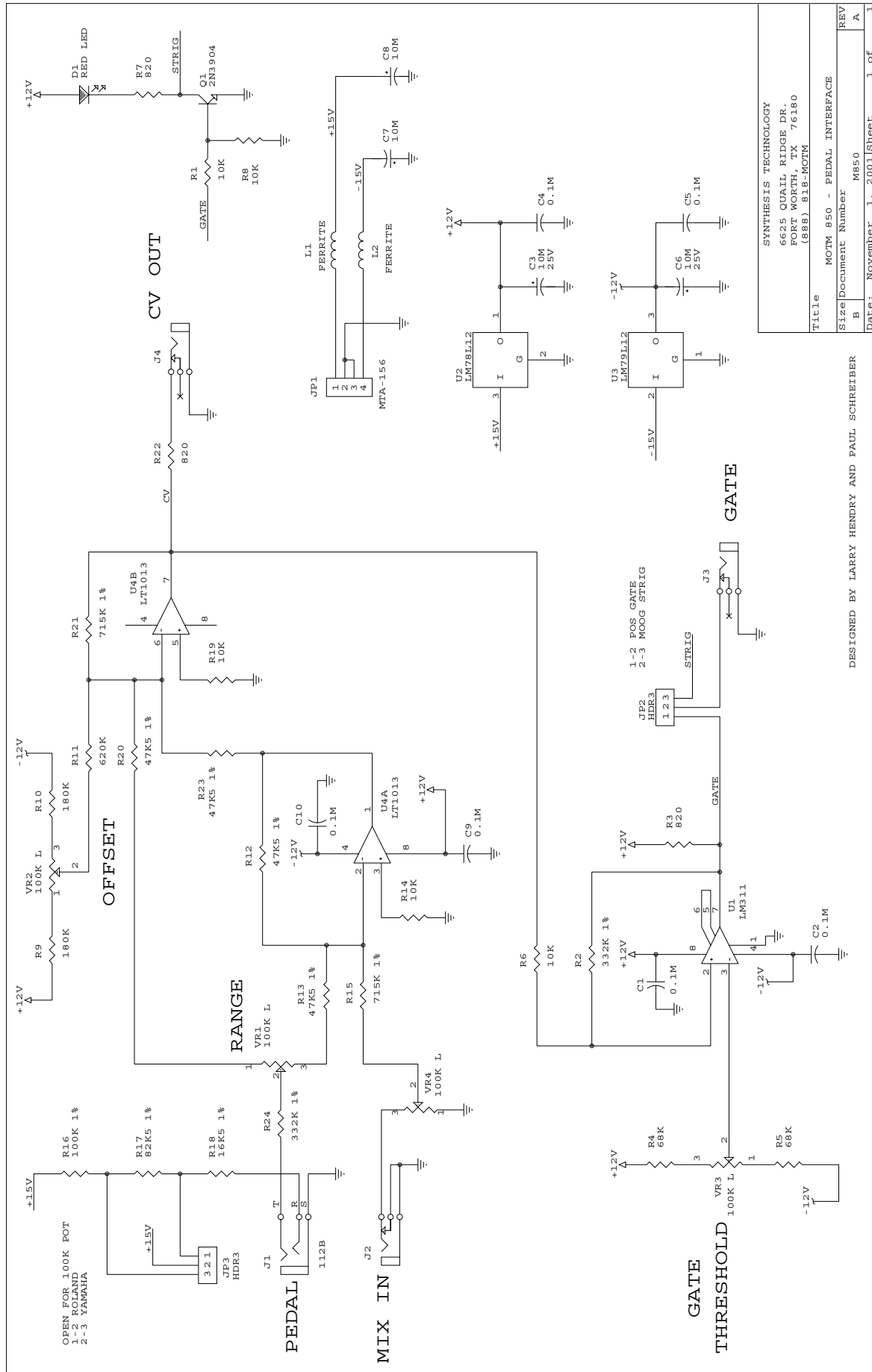

SYNTHESIS TECHNOLOGY  
 6625 QUAIL RIDGE DR.  
 FORT WORTH, TX 76180  
 (888) 818-MOTM

Title MOTM 850 - PEDAL INTERFACE  
 Size Document Number M850  
 B A  
 Date: November 1, 2001 Sheet 1 of 1

DESIGNED BY LARRY HENDRY AND PAUL SCHREIBER

