

**synthesis  
technology**

**MOTM-440 Discrete OTA Lowpass Filter  
Assembly Instructions & Owner's Manual**

Synthesis Technology  
6625 Quail Ridge Dr.  
Fort Worth, TX 76180  
(817) 498-3782  
[www.synthtech.com](http://www.synthtech.com)

March 25, 2000

# MOTM-440 PARTS LIST

Please carefully check that all parts are in your kit. If you have a suspected shortage, please call or email. If you get free extra stuff, keep it for next time.

**Capacitor** bag, containing the following 16 parts:

4ea 10mfd, 25V or 50V Electrolytic	C5, C6, C11, C13
4ea 1000pf axial polystyrene	C7, C8, C9, C10
3ea 3M3 50V non-polar Electrolytic	C3, C14, C15
1ea 1000pf yellow box (marked 1N or 102)	C16
4ea 0.1mfd (marked 104) ceramic axial	C1, C2, C4, C12

**Resistor** bag, containing the following 63 parts:

11ea 10K (brown, black, orange)	R10, R12, R13, R20, R26, R32, R38, R42, R43, R44, R45
8ea 220 ohm (red, red, brown)	R21, R22, R27, R28, R33, R34, R39, R40
6ea 15K (brown, green, orange)	R18, R24, R30, R36, R49, R50
4ea 100K 1% (brown, black, black, orange)	R1, R2, R46, R47
4ea 150K (brown, green, yellow)	R17, R23, R29, R35
4ea 1K5 (brown, green, red)	R19, R25, R31, R37
4ea 100K (brown, black, yellow)	R5, R6, R7, R61
3ea 1K (brown, black, red)	R16, R51, R53
3ea 51K1 1% (green, brown, brown, red)	R3, R4, R52
2ea 68K (blue, gray, orange)	R9, R15
2ea 1M (brown, black, green)	R11, R48
2ea 200K (red, black, yellow)	R14, R62
2ea 20K (red, black, orange)	R41, R58
1ea 221K 1% (red, red, brown, orange)	R8
1ea 6K8 (blue, gray, red)	R55
1ea 3K6 (orange, blue, red)	R54
1ea 44K2 1% (yellow, yellow, red, red)	R56
1ea 330K (orange, orange, yellow)	R59
1ea 2K2 (red, red, red)	R60
1ea 100 ohm (brown, black, brown)	R63
1ea 1K 1% +3300PPM tempco	R57 ( <i>MOUNTS ON TOP OF U14</i> )

**IC** bag, containing the following 29 parts:

13ea BC550C NPN transistor	Q1 – Q13
2ea 1N4148 diodes	D1, D2
1ea MXL1013 dual op amp	U1
3ea TL072ACP dual op amp	U2, U3, U4
5ea SSM2220 dual PNP transistor	U5, U6, U8, U10, U12
4ea SSM2210 dual NPN transistor	U7, U9, U11, U13
1ea CA3086 NPN transistor array	U14

- Misc #1 bag, containing the following 5 parts:**
  - 2ea Axial ferrite beads (plain, gray things)L1, L2
  - 1ea MTA-156 power connector JP1
  - 1ea SPDT (ON-ON) toggle switch SW1
  - 1ea 20K Bourns trimpot TP1
  
- Knobs, 7ea, ALCO PKES90B1/4**
  
- Jacks, 8ea Switchcraft 112A**
  
- Pots, 7ea containing the following:**
  - 1ea 100K cermet Spectrol 149 VR1
  - 3ea 100K conductive plastic log Spectrol 148 VR2, VR3, VR4
  - 3ea 100K conductive plastic Bourns 95A1 VR5, VR6, VR7
  
- Front panel**
  
- Mounting bracket**
  
- Wire bag, containing the following 13 wires:**
  - 3ea RG-174 coax, 4 ½ inches
  - 1ea RG-174 coax, 7 inches
  - 3ea 2-wire set, 22ga. 6 inches (orange/white)
  - 2ea 2-wire set, 22ga. 3 inches (red/black)
  - 2ea 3-wire set, 22ga, 4 inches (white/orange/gray)
  - 1ea 3-wire set, 22ga. 7 inches (red/black/white)
  - 1ea Power Cable, 20"
  
- Hardware bag, containing:**
  - 4ea #8-32 x 3/8 black screws (for mounting module to rack)
  - 4ea #6-32 x 1/2 zinc screws (for attaching pc board to bracket)
  - 4ea 1/4 inch aluminum spacers
  - 6ea #6 KEPS nuts (2 for attaching bracket to front panel, 4 for pc board)
  - 6ea small tie-wraps
  
- Organic Solder**
- No-clean Solder**
- PC Board, MOTM-440**

## GENERAL INFORMATION

Thank you for purchasing the MOTM-440 Discrete OTA Lowpass Filter. If you have any issues concerning the building or use of the kit, please contact us at (817) 498-3782 or by email: synth1@airmail.net.

This kit should take the average builder between 4 to 5 hours. The VCF kit contains many different resistors and special parts. However, please remember this is NOT a speed contest; it is an accuracy contest. There is no rule that you have to complete the entire kit in one day (as long as you wash the flux off!).

Successful kit building relies on having the proper tools. Here is a list of what you will need to build your MOTM-440:

- Soldering iron, 50W max power
- Needle-nose or chain-nose pliers
- Diagonal cutters
- Allen key set for securing the knobs (1/16" or 1.6mm)
- Magnifying glass: to read the capacitor codes and to inspect solder joints
- Lead bending tool (optional, but makes the job go much faster)
- DVM (Digital Volt Meter) or oscilloscope (to check the output)
- #1 Philips screwdriver
- Fingernail brush for washing off the organic flux
- Old towel for blotting dry pc board
- Small amount of heat-sink compound (not supplied!)

For more information of tools used and suggestions, see the MOTM FAQ and Tutorial pages at <http://www.synthtech.com>.

You also may find it useful to purchase heat-shrink tubing (1/8" diameter, 2:1 shrink ratio) and solder. Just be sure it is NOT rosin-based flux!

## HOW TO FOLLOW THE DIRECTIONS

Please read the entire instruction before proceeding. There may be valuable information at the end of the instruction. Each instruction has a check box  next to it. After you complete the instruction, check the box. This way you can keep track of where you are in the process.

## VERIFY THE PARTS LIST

- Verify that all of the parts are in the kit as shown on the parts list.

## A WORD ON SOLDERING

There are 2 very different types of solder used in the kit. Most of the soldering uses 'Organic Flux' solder. ***This is strictly for use on the pc board, and is NOT to be used on the front panel wiring!***

In order for solder to 'stick' to the copper, a chemical called 'flux' is embedded in the solder. The flux leaves a residue on the pc board that should be cleaned with warm water. **DO NOT USE SOAP OR OTHER CLEANSERS.** Most of the parts in the kits are 'waterproof' and can be washed in the sink. The flux is OSHA approved for flushing down the drain, so don't worry about that! A soft brush is used to gently scrub the board. We recommend a 'fingernail brush', which is about 1" x 2" and can be found for about \$1.

The other type of solder is called 'No Clean Flux'; because as the name implies it does, not require washing. This solder is used for wiring the pots, switches, jacks, etc. This solder is harder to use on the pc board; because even when melted, it is not very fluid (about the consistency of toothpaste). We will use it **VERY SPARINGLY** on the pc board.

OK, let's get started on the board!

### PART #1: SOLDERING THE RESISTORS

Since there are more resistors than anything else, we will start here. If you do not know the resistor color code, refer to the parts list. Resistors are not polarity sensitive, but the board will be easier to debug (and look nicer) if you point the first color band in the same direction for all the parts. The color code is also in the README FIRST document that every customer receives with his or her first order.

You will start by soldering in ALL of the resistors.

- Find the **RESISTOR** bag.
- Find the MOTM-440 blank pc board. There is a copy (larger than actual size) of the silkscreen which shows where the parts go at the end of this document. It will be useful if you locate the part on the print first, put the part in the board, then 'check off' the silkscreen. All parts are inserted from the side of the board with the white silkscreen (the "top" side).

NOTE: some reference designators are under the resistor! Be careful.

- We will stuff the resistors by value to make things easier. The resistors (and other long-leaded parts) are inserted on a 0.4 inch spacing. The important thing is to be sure that the part is sitting all the way down on the board. Push the leads in the holes, push the part on the board, and then bend the leads on the bottom outwards to a 45 degree angle (roughly!). This is called 'cinching the leads': and keeps the part from falling out! From the bottom of the board, solder (using the organic flux), applying heat to the pad for about a half second first, then applying just enough solder to make a small puddle that looks like a tiny pyramid. Enough solder should

flow in the hole such that on the top (component) side, a small amount is on the top pad as well

The rule of soldering: don't use too much, you can always add more! Cut the leads flush with the top of the solder joint with your diagonal cutters.

***NOTE: save the large black 1K TEMPCO resistor for later!***

Locate the 10K resistors (11pcs). Solder the resistors into R10 (left of VR2), R12 and R13 (below R10), R20 (right of Q11/Q13), R26 (right of Q9), R32 (above SW1), R38 (left of D1/D2), R42 (right of Q2), R43 (above J1), R44 (right of Q8) and R45 (right of C7).

- Locate the 220 ohm resistors (8) and solder into R21 (below Q12), R22 (left of U13), R27 (right of Q9), R28 (left of U11), R33 (right of Q7), R34 (left of U8), R39 (left of D1/D2) and R40 (left of U6).
- Locate the 15K resistors (6) and solder into R18 (by Q13), R24 (by Q10), R30 (right of C10), R36 (right of Q3), R49 (left of U5) and R50 (by C5).
- Locate the 100K, 1% **resistors** (4) and solder into R1 and R2 (by U1) and R46/R47 (left of U3).
- Locate the 150K resistors (4) and solder into R17 (by Q13), R23 (by Q10), R29 (by Q7) and R35 (by Q4).
- Locate the 1K5 resistors (4) and solder into R19 (below JP1), R25 (by C7), R31 (by C10) and R37 (by Q1).
- Locate the 100K resistors (4) and solder into R5/R6/R7 (left of VR3) and R61 below SW1).
- Locate the 1K resistors (3) and solder into R16 (by J8) and R51/R53 (at top edge).
- Locate the 51K 1% resistors (3) and solder into R3/R4 (left of U4) and R52 (by C6).
- Locate the 68K resistors (2) and solder into R9 (below VR2) and R15 (below VR3).
- Locate the 1M resistors (2) and solder into R11 (by VR1) and R48 (by SW1).
- Locate the 200K resistors (2) and solder into R14 (by VR1) and R62 (left of U9).
- Locate the 20K resistors (2) and solder into R41 (top edge) and R58 (above J3).
- Locate the 221K 1% resistor and solder into R8 (by U1).

- Locate the 6K8 resistor and solder into R55 (by VR3).
- Locate the 3K6 resistor and solder into R54 (below L1).
- Locate the 44K2 1% resistor and solder into R56 (by TP1).
- Locate the 330K resistor and solder into R59 (by R56!).
- Locate the 2K2 resistor and solder into R60 (by C16).
- Locate the 100 ohm resistor and solder into R63 (above TP1).

## **PART #2: BOARD WASH #1**

- Verify all the resistors are in the correct position.
- Verify all the resistors are flat on the board. Correct if needed. Check solder joints.
- Wash the board in warm water, gently scrubbing *both* sides. **DO NOT USE ANY SOAP! Just water!**
- Shake the board a couple of times, blot dry with an old towel (the leads will frazzle a good towel). Let dry at least 15 minutes.
- Take a little break! You are about 1/3rd of the way finished.

## **PART #3: CAPACITORS & board wash.**

- Locate the **CAPACITOR** bag. Set the polystyrene 1000pf caps (the big silvery ones with the long, thin leads) aside. ***THESE CAPS ARE SOLDERED IN AFTER THE ICs!***
- Locate the 1000pf (1N) yellow box cap and solder into C16.
- Locate the 3M3 50V non-polar caps (3) and solder into C3, C14 and C15.
- Locate the 0.1 axial caps (4) and solder into C1, C2, C4 and C12.
- Locate the 10µfd electrolytics (4). Note that there is a stripe on the **NEGATIVE** terminal. The pc board has a + on the **POSITIVE** terminal. Carefully stick the

capacitors into C5, C6, C11 and C13 with the stripe *away* from the + pad on the board.

- Wash the board again, gently scrubbing both sides. Use **ONLY** warm water!

#### **PART #4: MISC and IC STUFF**

Almost done with the parts on the pc board! This will finish up the soldering with the organic flux. Save the trim pot for later.

- Locate the **MISC #1** bag and the **IC** bag.
- Locate the ferrite beads (2). They are axial parts, gray colored with no markings. These are non-polar, and are soldered into L1 and L2 (by JP1).
- Locate the MTA-156 power connector. Solder into JP1. Note that the connector has a 'locking tab' on one side. This side is the "inside" facing relative to the pc board. Note the silkscreen symbol for JP1 has a line on one side, indicating this is the side where the locking tab goes.
- Locate the MXL1013 op amp. Solder into U1. Note that all ICs are pointing "down" towards the bottom edge of the pc board. The IC will have a 'notch' or indentation in the top by Pin #1.
- Locate the 1N4148 diodes. Notice they have a black band near one end. This is the cathode, and there is a matching band on the silkscreen for D1 and D2. Solder the diodes, with the banded end pointing down.
- Locate the TL072 op amps (3). Solder into U2, U3 and U4.
- Locate the SSM2220 dual transistors (5). Solder into U5, U6, U8, U10 and U12.
- Locate the SSM2210 dual transistors (4). Solder into U7, U9, U11 and U13.
- Locate the BC550C transistors (13) Match the flat side of the part to the flat side shown on the silkscreen. Place the transistor in the holes, but do **NOT** press the transistor all the way to the pc board. Leave about 0.1 inch of the leads exposed between the pc board and the underside of the transistor. Solder into Q1 – Q13.
- Locate the CA3086 transistor array. Solder into U14.
- Apply a small bit of solder to the via holes. These are the small pads that allow traces to "change sides" of the pc board. **DO NOT SOLDER PADS FOR THE REMAINING COMPONENTS!!**



## PART #5: FINAL BOARD WASH & INSPECTION

- Verify all the parts are in the correct locations. Make sure all of the ICs are pointing the same direction. Make sure all of the transistors are facing the same direction.
- Inspect the solder joints. Any solder shorts? Too much solder? Missing joints?
- Wash the board under warm water. Scrub gently. Dry.

**THIS IS A GOOD STOPPING PLACE TO REST OR PUT THE KIT AWAY UNTIL LATER.**

*You are now finished with the Organic flux solder. All soldering past this point is using the No-Clean solder. You do not have to wash the board anymore.*

## PART #6: FINISHING THE PCB

You will now solder in the remaining parts on the pcb in preparation for wiring to the front panel. USE THE NO-CLEAN SOLDER. BE CAREFUL!

- Locate the blue trim pot. Solder it into TP1. Be sure it is flat on the pc board.
- Locate the 4 1000pf polystyrene caps. Carefully bend the leads into the holes and be sure the cap is flat on the pc board. Solder into C7, C8, C9 and C10.
- Locate the Spectrol pots (not the blue ones, the other ones!) There are 3 type 148-9609-104 100K pots and 1 type 149 100K linear pot. The type 149 pot goes into VR1, and the 3 type 148-9609-104 pots go into VR2, VR3 and VR4. Be sure they are flat and sticking out perpendicular to the pc board.
- Locate the 4 pieces of RG-174 black coax cable. Again, note that one end has longer wires stripped than the other. The short ends will go in the pc board in locations J4, J5, J6 and J8. Look at the pc board. Notice that in the coax positions, there is a large hole pad (lower pad) and a smaller pad (top hole). The braided wire is soldered into the larger hole. The smaller, inner conductor goes in the top hole. BE SURE THE **SHORTER** BRAIDED END GOES INTO THE PC BOARD.

**The 1 LONG coax cable solders into J4.** The 3 SHORT coax cables go into the other locations. Solder each coax cable into the holes. Attach a tie-wrap to secure the coax cable flush to the board. The tie-wrap goes down, into the left hole and up through the right hole. Secure and trim off any excess.

- Find the 2 orange/white/gray twisted wires. They are soldered into VR6 and VR7. Look at the pcb silkscreen, and note that there are the numbers 1, 2 and 3 beside the

box around the 3 pads. Solder the White wire into the #1 pad, the Gray wire into the #2 pad, and the Orange wire into the #3 pad.

- Find the long red/white/black wire. It solders into VR5. Solder the White wire into pad #1, the Black wire into pad #2 and the Red wire into pad #3.
- Find the 2 red/black twisted wires. They go into J2 and J3. Solder the Red wire into pad #1 and the Black wire into pad #2.
- Find the 3 orange/white twisted wires. They solder into J1, J7 and SW1. In all cases, solder the White wire in pad #1 and the Orange wire into pad #2.
- Find the black TEMPCO resistor. ***It goes on top of U14!*** You will notice the 2 large holes on the ends of U14 (the CA3086). But first, you will need to apply a very small amount of heat-sink compound to the top of U14. Heat-sink compound can be found at Radio Shack, Allied, Mouser, DigiKey, Maplin, Farnell and most other electronic supply stores. The key is not to use too much! The TEMPCO resistor will “squish” the heat-sink compound as it is lowered ***to rest flat on top of U14.*** Once the TEMPCO is resting flat on U14, with the heat-sink compound, solder the 2 leads of R57.

***YOU ARE NOW FINISHED WITH THE PC BOARD WORK! BREAK TIME.***

## **PART #7: FRONT PANEL PREPARATION**

You will now attach components to the front panel. It is HIGHLY recommended that you use a set of hollow shaft nut drivers, NOT PLIERS, to tighten the nuts. This prevents scratching. NOTE: all references to part orientation is from the REAR of the panel.

- Locate the 8 Switchcraft jacks. Notice that from the rear, there is a beveled corner. This corner is ALWAYS CONNECTED TO GROUND, USUALLY WITH A BRAIDED CONDUCTOR. Each jack has a flat washer, a lockwasher, and a ½” hex nut. Remove the nuts and washers from each jack. Place aside. Keep the lockwasher on the jacks.
- Insert the 8 jacks/lockwashers, with the beveled corner in the ***upper right*** corner, into the 8 holes. Place the flat washer on the jack, then the hex nut. Hold the jack with one hand on the backside, keeping it ‘square’. Tighten the hex nut with a nut driver. NOTE: when tight, not much of the exposed threads of the jack are exposed.

You are now ready to attach the pc board to the bracket and then wire up to the panel.

## PART #8: ATTACH PC BOARD TO BRACKET/PANEL

- ❑ In the **HARDWARE** bag, locate 4 #6-32 x 1/2 screws, 6 #6 KEPS nuts, and 4 spacers.
- ❑ Locate the mounting bracket. The pc board attaches to the bracket, with the 4 screws threading from the top of the board, through the spacers, through the bracket, and then out the bottom of the bracket. The #6 KEPS nut attaches on the bottom of the bracket. Note the bracket has 2 long mounting flanges with a hole in each. These attach to the 2 threaded studs sticking out of the rear of the panel. The 4 pots each stick in its panel hole when the bracket is screwed down on the 2 threaded posts.

Attach the pc board to the bracket. The flanges will point upwards when the pc board is sitting on the bracket. Note that the bracket holes for the pc board are actually oblong. This is to allow adjustment for the pc board to firmly press up against the back of the panel. As a start, set the 4 screws **ALL THE WAY TO THE LEFT** of the oblong holes. **Loosely** tighten the 4 KEPS nuts on the bottom.

- ❑ **THIS IS A VERY IMPORTANT STEP, SO PAY ATTENTION AND READ ALL OF IT BEFORE PROCEEDING!**

Note that each of the 4 pots on the pc board have 2 hex nuts and a flat washer. Remove the first hex nut and the washer. Set aside.

What you will do now is adjust the remaining hex nuts so that when the bracket is all the way down on the panel's threaded studs, all the pot hex nuts touch the rear of the panel.

Screw (by hand) each hex nut on the pots so that it is all the way on (touching the face of the pot). Now, pick up the pc board/bracket assembly and carefully slide it over the 2 threaded studs, making sure the pots are aligned in the holes. Use 2 #6 KEPS nuts and tighten the bracket to the panel.

- ❑ Loosen the 4 KEPS nuts on the bottom of the bracket. Slide the pcb **ALL THE WAY TO THE RIGHT AS FAR AS IT WILL GO**, so that the 4 pot nuts are all pressing against the panel. By hand, put hex nuts on the outside threads of VR1 and VR4 to keep the pc board in place. Now, tighten the 4 KEPS nuts on the bracket. The pcb and bracket should be secure, with no gaps visible between the panel and the pot nuts. You may need to loosen the nuts on the pots, so that they are touching the back of the panel. Again, make sure each pot's nut is touching the back of the panel (no gaps!). There will be a gap from the edge of the *pc board* to the panel.
- ❑ Remove the hex nuts on VR1 & VR4. For all of the pots, first put on the flat washer, then the hex nut. Tighten with a ½" nut driver. **DO NOT OVERTIGHTEN THE PLASTIC THREADS OF VR2, VR3 and VR4!!**

## PART #9: FINISH WIRING TO THE PANEL

Please read the following instructions carefully. In order to neatly attach the many wires to the front panel components, the wires are soldered in a specific order.

Find the SPDT toggle switch. Insert the switch into the panel hole labeled BASS. Tighten the outside hex nut, but **DO NOT OVERTIGHTEN!!** Be sure the switch is oriented so the lever operates “up and down” and not “side-to-side”!

Locate the 3 blue Bourns 91A panel pots. These solder to the 3 wires in VR5, VR6 and VR7. Look on the rear of the pot: you will see 3 very small numbers by the solder lugs. The #1 lug is on the **RIGHT**, the #2 lug is in the **CENTER**, and the #3 lug is on the **LEFT**. These lugs correspond to the pad numbers on the pcb wires.

First, solder the pot VR5 on the wires. The Whites wire is lug #1, the Black wire is lug #2 and the Red wire is #3. Then solder pots VR6 and VR7. In both cases, the White wire is lug #1, the Gray wire is lug #2 and the Orange wire is lug #3.

Once the wires are attached, insert VR5 into the **FREQ** panel hole, VR7 in the **FM1** hole and VR6 in the **FM2** hole. Add a flat washer and hex nut. Tighten with a ½” nut driver.

Now you will solder to the BASS mode switch. The SW1 White wire goes to the **CENTER** lug. The Orange wires goes to the **BOTTOM** lug. The **TOP** lug is not used.

Now you will solder to the 8 jacks. Each jack has 3 lugs: from the rear we will refer to them as **LEFT**, **TOP**, and **BEVELED**. The **TOP** lug is for the switched contact: this is a **NC** (normally closed) contact that is opened when a plug in inserted.

Solder the coax in J8 to the **OUT** jack. The braid goes to the **BEVELED** lug. The inner conductor goes to the **LEFT** lug. This is true of **ALL** coax wires.

Solder orange/white wire in J7 to the **RES** jack. The Orange wire goes on the beveled lug. The White wire goes on the **LEFT** lug.

Solder the coax in J6 to the **IN 3** jack.

Solder the red/black wire in J3 to the **FM2** jack. Black wire to the beveled lug, red wire to the left lug.

Solder the coax in J5 to the **IN 2** jack.

Solder the red/black wire in J2 to the **FM1** jack.

- Solder the long coax in J4 to the IN 1 jack.
- Solder the orange/white wire in J1 to the 1V/OCT jack.
- Rotate all of the front panel pots fully counter-clockwise. Locate the **KNOBS**. Notice each knob has a white line on it. Place the knob on the pot shaft, align the white line to the '0' tick mark, and tighten the hex screw. The silver part of the knob has a protective clear plastic overlay that can be removed if desired. Gently rub with your fingernail across it and it will peel off. Use the 2 extra wire ties to "bundle" the coax wires together and the wires to the blue Bourns pots together. Trim off any excess.

\*\*\*\*\*  
**CONGRATULATIONS! YOU HAVE FINISHED BUILDING THE MOTM-440!**  
 \*\*\*\*\*

All that's left to do is test it! But before we do, please read the following Theory of Operation.

## THEORY OF OPERATION

The MOTM-440 uses 4 identical 1-pole VCFs in series. Each individual VCF is a low-pass filter, which is nothing more than a simple RC section. The difference is the 'R' (resistance) is implemented as an OTA (Operational Transconductance Amplifier), which allows for voltage control of the cutoff frequency.

There are many OTAs that are available (such as the NE5517 and LM13600 used in other MOTM modules), but in this case, the OTAs are done with sets of matched transistors. Why? We wanted to emulate the "classic" SSM2040 filter chip found in the Prophet 5 Rev 2, the Voyetra 8, and other early synths. The MOTM-440s OTAs are similar to the OTA sections inside the SSM2040 chip.

An OTA is a *transconductance* operational amplifier. The output is a *current*, which is based on 2 things: the differential input voltage and a control current. By varying the control current, the effective resistance into the filter cap changes, and hence the cutoff frequency.

Since the filter portion is 4 identical stages in series, we will only discuss the first stage. The first OTA is PNP current mirror U6, differential stage U7, filter cap C10, Darlington current buffer Q2/Q3, and a 500ua current sink Q4.

The audio input is first attenuated by resistor divider R42/R39 by a factor of ~0.02. The input summer (discussed later) has an attenuation factor of .68, so the total gain reduction is  $(0.02)(.68) = 0.014$ . So, a 5V input is reduced to  $(5)(0.014) = 70\text{mv}$ . Why?

Let's look at the differential pair of NPN transistors inside U7. Since the emitters are tied together, the control current IC0 is a sum of the 2 individual emitter currents. If we then

assume high beta transistors, the collector currents will equal the base currents. Now, we notice that the base of the “left side” transistor is tied to ground through R40. Labeling the transistors L for the Left and R for the Right, we note:

$$V_{beL} - V_{beR} = 0 \text{ (due to R40) - } V_{input} \text{ and}$$

$V_{eL} = V_{eR}$  the emitter voltages must be equal since they are tied together.

Digging around in EE101 textbooks for the transistor equations, we use the above facts to solve for the collector current:

$$I_c = I_{C0} / [1 + e^{(V_{input}/V_t)}]$$

Where  $V_t$  is called the thermal voltage (approx. 26mv at room temperature) and  $I_{C0}$  is our filter section control current. Since  $V_t$  is small, we must scale  $V_{in}$  or the denominator term quickly gets huge. At 70mv peak,

$$I_c = I_{C0}/15.76$$

So as the audio input gets larger, the collector current gets smaller. If  $V_{in}$  exceeds say 100mv, the collector current does not change much. That’s the reason for the input attenuation.

In summary, you can see that the overall gain is set by  $I_{C0}$ , which is a simple linear function: a VCA.

To form the LPF, we add a cap C10 to ground on the “right” collector. This forms a 1-pole integrator. The output current is buffered by a Darlington pair Q2/Q3. In a “new” design, this buffer is usually a single JFET. But, again we are trying to recreate the same OTA structure in the SSM2040, so as in that bipolar chip we use 2 transistors instead.

In order to swing both positive and negative on the emitter of Q3, we attach a constant current sink of 500ua. This is formed by resistor divider R35/R36 that places the base of Q4 at ~-13.6V. The emitter is 1 diode drop below that, or ~-14.2V. Since R37 is tied to -15V, the voltage across it is about 0.8V which makes the current  $(.8)/(1500)$  or about 500ua.

To make a 4-pole filter, we just connect 4 stages in series.

Now, we need to control our filter to get the “usual” response of 1V/octave. This is done by op amp U1A, op amp U3a, and a CA3086 NPN transistor array.

First, we sum all of the external control voltages together. U1a is a special low-offset, low-drift op amp. U3b forms a ‘reversing attenuator’. The voltages are summed and fed to a divider network of TEMPCO resistor R57 and the trim pot TP1. This divider is necessary as shown in the earlier discussion: we want to operate the exponential converter transistor U14e in its linear region. The TEMPCO is used to counteract the  $V_t$  term:  $V_t$  will change about -2mv/C. So, we have a “bad” resistor that changes the divider ratio with temperature the opposite sense. That is why the TEMPCO is placed in thermal contact with U14.

Instead of tying R57 to ground, it is biased up by R58/R59/U1b to 0.85V, which is just barely above 1 V<sub>be</sub> drop to keep Q14Ee from ever saturating. Each OTA section needs a control current, which needs to be a current sink. The remaining NPN transistors in U14 are in “parallel” as 4 identical current sinks. U3a and R62 form the reference current of about 75ua. As the base-emitter voltage of U14 changes, the 4 control currents change exponentially and hence the filter’s cutoff frequency changes. TP1 is set to give 1V/oct response.

The ‘440 has voltage-controlled resonance. This is done by adding a VCA stage (U5) into the audio feedback path (R41/C11) to modulate the feedback level into the first stage. The VC Q voltage is generated by U2b, which is a non-inverting gain of 2. The 2 diodes D1/D2 are used to raise the op amp’s output 2 V<sub>be</sub> drops above U5, keeping it out of saturation. The control current for the VCA is just plain resistor R49. AS the VC Q sweeps from 0-5V, the control current sweeps from ~20ua to ~650ua.

The audio summer is a standard inverting op amp U2a. The audio is split into two paths: the “normal” audio goes to the first filter stage, but there is a resistive network (R48/C13/R52) feeding the other input of the VC Q VCA. This allows a ‘bass boost’ to occur if R48 is shorted by SW1. The additional audio feeding the first stage (at the opposite polarity) increases the output level at higher Q settings. Normal OTA filters (even the SSM2040) drop the output level as Q is increased. This is an exclusive MOTM-440 feature!

The audio output is buffered and amplified by a factor of 10 by U4a.

## TROUBLESHOOTING

If your MOTM-440 does not work, please verify ALL of the following before contacting us. The following reference directions assume that you are looking at the pc board with the panel to the right and the power connector to the left.

- All of the ICs are pointing the same way and all notches are ‘down’. Diodes D1 and D2’s bands are both pointing “down”. All 13 (!) transistors’ flat sides are facing the panel. AND...be SURE you didn’t swap a SSM2210 and a SSM2220!
- The braided wire on the coax goes to the beveled side of the jacks.
- The parts are in the right places, and the panel pots/switch is wired correctly.
- No solder shorts or missing joints.

## USE OF THE MOTM-440 VCF

The MOTM-440 needs to be set to 1V/oct response by adjusting TP1.

- a) set all the IN pots to 0.
- b) set FREQ pot to 5 (straight up)
- c) set RES to 10
- d) set BASS to NORMAL

Apply a known 1V/oct control voltage into the 1V/OCT jack. The filter will self-oscillate with an initial frequency set by the FREQ pot. Using a small screwdriver, set TP1 to track as close as possible. Note that the setting will be approximate: this is not a VCO substitute!

The MOTM-440 is a “stand alone” module that can be used for filtering just about any audio source (you can't plug a guitar or mic directly into it, but use a 'direct box' or preamp first!).

The response is always a low-pass filter: this means most of the frequencies above the cutoff are filtered out. The 24db/octave slope means that frequencies 1 octave above cutoff are reduced 24db (a factor of 0.06) and 2 octaves above are reduced 48dB (a factor of 0.004). The 12dB/oct MOTM-420 reduces frequencies 1 octave away by a factor of 0.25. Therefore, a rule of thumb is a 24dB/oct filter is 4 times more effective in reducing the higher harmonic content!

Use of the '440 is straightforward. Audio signals are plugged into IN1 – IN3 and are set by corresponding level controls. Note that it is possible to over-drive the filter with multiple VCO inputs (10V pk-pk). The control voltages are plugged into 1V/OCT, FM1 and FM2. FM1 features a 'reversing attenuator': the pot can invert the input voltage (on the -5 setting) or pass it through (the +5 setting). The filter is designed so an *increasing* control voltage *increases* the cutoff frequency. And remember, increasing the cutoff means more treble passes through. The reversing attenuator, when set in the - region, does the opposite: increasing voltage decreases the cutoff.

If no voltage is patched into the RES jack, the RES pot sets the resonance. At settings past about 9, the filter will self-oscillate. This generates a sine wave. If you patch a control voltage into the RES jack, ***the RES pot acts as an input attenuator***. Note that the RES control is set for a 0 to +5V range for min to max resonance.

The BASS switch can be set to act like a 'normal' OTA filter, which reduces output level as resonance is increased. In the ENHANCE position, the output level is boosted to compensate for the loss at higher RES settings.



# SPECIFICATIONS

## MOTM-440 DISCRETE OTA FILTER

Control Voltage input levels	-7V to +7V
Cutoff frequency range	20Hz to 8Khz
Output impedance	1000 ohms, nom.
Audio input level	50mv pk-pk min, 11V pk-pk max.

### CONTROLS

FREQ	sets initial cutoff frequency at 0V input
RES	sets resonance (Q) or acts as RES attenuator
FM1	sets gain of FM1 CV from -2 to +2
FM2	sets gain of FM2 CV from 0 to 1.
IN1-IN3	sets audio input level for each IN
BASS	sets NORMAL or ENHANCE bass response

### GENERAL

Power Supply	-15VDC @ 25 ma nominal +15VDC @ 20 ma nominal
Size	2U x 5U 3.47" x 8.72" 88.1mm x 221.5mm
Depth behind panel	4.375 inches (111mm)

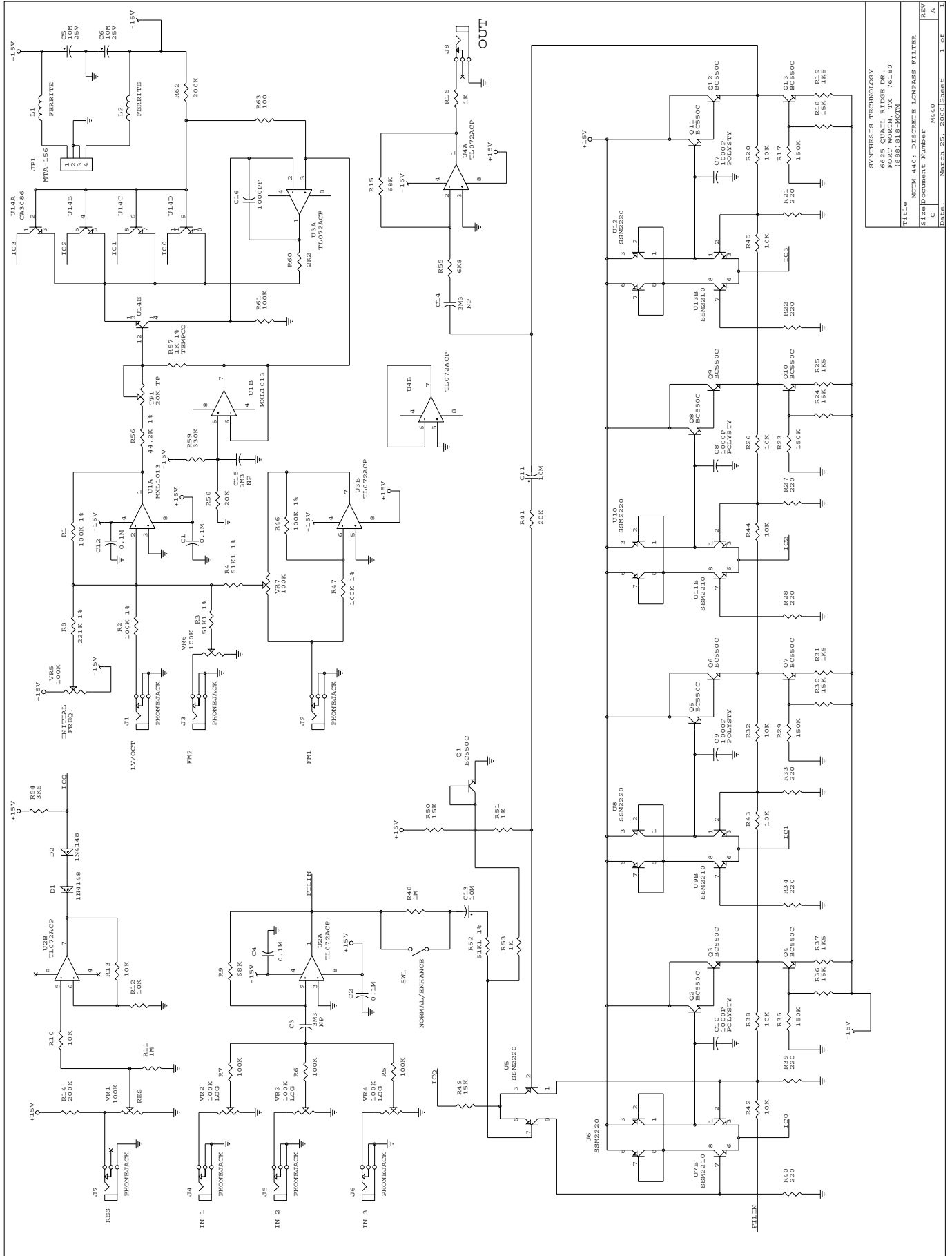

SYNTHESIS TECHNOLOGY  
 8000 N. CENTRAL  
 FORT WORTH, TX 76180  
 (817) 818-1071

Title: COMPASS FILTER  
 Date: 01/25/2000  
 Rev: A  
 Sheet: 1 of 1

SYNTHESIS TECHNOLOGY  
MOTM-440 OTA FILTER  
COPYRIGHT 2000  
REV B

WWW.SYNTHTECH.COM

